



## Wheel bearings



Technology

Development and product overview

The content of this brochure is not legally binding and is solely intended for information purposes. Insofar as is legally permissible, Schaeffler Automotive Aftermarket GmbH & Co. KG does not accept any liability in connection with this brochure.

All rights reserved. This brochure must not be duplicated, distributed, reproduced or made publicly accessible or otherwise published, either in whole or in part, without the prior written consent of Schaeffler Automotive Aftermarket GmbH & Co. KG.

Copyright ©  
Schaeffler Automotive Aftermarket GmbH & Co. KG  
July 2017

## Schaeffler in the Automotive Aftermarket – more innovation, more quality and more service.

### Schaeffler in the Automotive Aftermarket – four strong brands.

Whenever a vehicle needs to go to the garage, our products and repair solutions are usually first choice to fix them. With our four strong brands LuK, INA, FAG, and Ruville, we are a reliable global partner – offering repair solutions for passenger cars, light and heavy commercial vehicles as well as tractors.

Whether for the transmission, engine, or chassis – all products are based on a comprehensive systems approach. Innovation, technical expertise, and the highest material and manufacturing quality make us not only one of the leading development partners for vehicle manufacturers, but also a pioneering provider of value-retaining spare parts and complete repair solutions – always in Schaeffler quality. Our comprehensive portfolio includes products and repair solutions for clutches and clutch release systems, engine and transmission applications, and chassis applications. All components are optimally tuned to work together perfectly, and allow fast and professional parts replacement.

FAG offers everything needed for flawless wheel bearing replacement. The durable wheel bearings and innovative repair solutions reach from the classic wheel bearing set FAG WheelSet, to the FAG WheelPro (for a per-axle wheel bearing replacement), all the way to wheel bearing repair solutions for light commercial vehicles and pre-assembled units for trucks and trailers like the FAG RIU (repair insert unit) and the new FAG SmartSET.

### Schaeffler REPERT – the service brand for garage professionals.

Under the REPERT brand we offer a comprehensive package of services for the products and repair solutions of the LuK, INA, FAG, and Ruville brands. Looking for specific information or damage diagnosis? Are you in need of particular tools to make your everyday garage routine easier? Whether online portal, service hotline, installation instructions and videos, training seminars, or events – all technical services are provided in just one place.

SCHAEFFLER  
**REPERT**



Then simply register for free in just a few clicks at: [www.repxpert.com](http://www.repxpert.com).





## Contents

	Page
<b>1. History and introduction</b>	<b>6</b>
1.1 FAG – The original	7
1.2 Why FAG wheel bearings are worth it	8
1.3 How to recognise quality	9
<b>2. All-rounder wheel bearing</b>	<b>10</b>
<b>3. Construction and function of roller bearings</b>	<b>12</b>
3.1 Roller bearing types	12
3.2 Roller bearing design	13
3.3 Advantages and disadvantages of tapered roller bearings and ball bearings	14
3.4 Construction of compact bearing units	15
3.5 How a wheel bearing works	16
3.6 Bearing clearance and play	18
3.7 Lubrication	20
3.8 Seal systems	21
3.9 Rotational speed signal reading	22
<b>4. Wheel bearing generations</b>	<b>24</b>
4.1 Generation 1	26
4.2 Generation 2	29
4.3 Generation 3	32
<b>5. Repair solutions for the garage</b>	<b>33</b>
<b>6. Patents and innovations</b>	<b>34</b>
6.1 Orbitally formed shoulder	34
6.2 Snap ring	35
6.3 Face spline	36
6.4 Low friction torque seal (LFT)	37
<b>7. Outlook and innovative strength of FAG</b>	<b>38</b>

1883

Founding year of the company: Friedrich Fischer builds the first ball grinding machine, used to grind hardened steel balls in large batches with absolute spherical precision. Thanks to this innovation, the ball bearing's success spreads around the world.

1896

Friedrich Fischer submits a building application for a new plant – heralding the transition to industrial production of 10 million balls a week.

1899

On October 2, Friedrich Fischer dies of a stroke aged 50 and without heirs. With the death of the company's founder, 400 employees lose their driving force.

1905

The trademark "FAG", Fischer Aktien-Gesellschaft, is registered, and the "FAG" brand is born.

1909

Georg Schäfer buys the oldest company of the industry – "Erste Automatische Gußstahlkugelfabrik", formerly Friedrich Fischer – breathing new life into the business.

1980

Generation 2 wheel bearings are used in the series production of select vehicle types.

1965

For the first time, car manufacturers use Generation 1 wheel bearings in series production.

1948

Return of Georg and Otto Schäfer to the executive management – rebuilding the company from ruins.

1943 – 1945

Destruction of 85% of the Schweinfurt plant following 15 heavy bombing raids on Schweinfurt. Following the end of the war, disassembly of over 4,000 machine units.

1990

Generation 3 wheel bearings are used in series production in the automotive industry.

1994

FAG equips the space shuttle with new bearing types.

2001

Takeover of FAG Kugelfischer Georg Schäfer AG, Schweinfurt by INA-Holding Schaeffler KG. INA and FAG become the world's second largest rolling bearing manufacturer.

2007

The V150 high-speed train sets a new world record of 574.8 kilometres an hour with FAG bearings (cylinder roller bearings, four-point bearings and tapered roller bearings in engines and transmissions).

1993

FAG patents the invention of the orbitally formed shoulder, revolutionising the replacement of wheel bearings in garages with its production.

2000

The London Eye goes into operation using two FAG bearings one-metre in size and weighing tonnes.

2003

INA, FAG and LuK form the "Schaeffler Group".

2005

FAG enters the automotive after-market on the 100th anniversary of the FAG brand with its wheel bearing replacement programme.

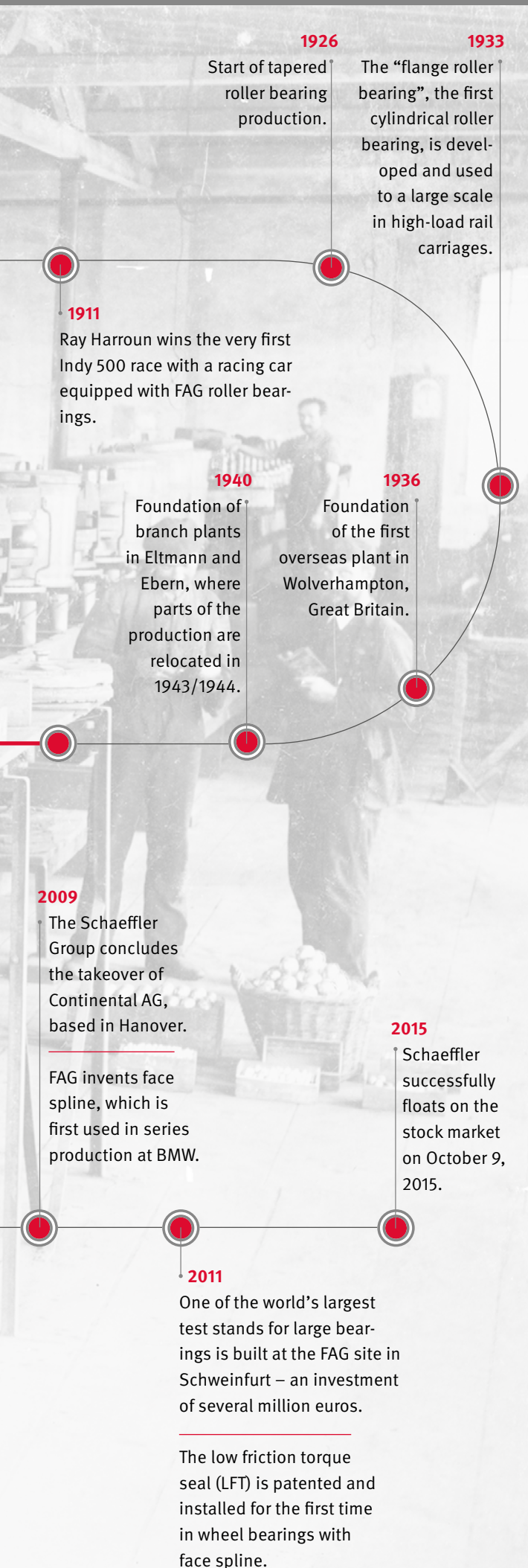

## 1.1 FAG – The original

Friedrich Fischer was a clever man. After trying for some years to produce the perfect metal ball, he made the breakthrough in 1883. He developed the first “ball mill”, initially to produce better balls for use as bearings in bicycle axles. He was soon able to improve the first machine, and called it the “ball milling machine”. It formed the basis for another invention, which still exists today: the roller bearing.

With Fischer’s machine, hardened steel balls could achieve a spherical precision down to 0.02 millimetres. This made the bearings fitted with them particularly smooth running and long-lasting. Friedrich Fischer could now produce balls with minimal deviation from the ideal shape in very large batches. This signalled the birth of the automated roller bearing industry.



### In great demand: long-life bearings

Although journal bearings had previously been used, since the advent of industrialization in the 19th century, there was a need for bearings that also performed well at low speeds. And that was a problem for journal bearings, which wore down very quickly, and always needed very good lubrication. The roller bearing runs more smoothly because it contains rolling elements. As a result, industrialization was able to gather pace, thanks to ball bearings from Kugelfischer as well. Today, roller bearings are standard throughout the automotive industry, and the technology of Friedrich Fischer has, of course, been further perfected. Since then, the primary goal of vehicle component development is efficiency – both in the production of the parts and their use in the vehicle.

### Modern components that the market needs

The wearing of individual parts should be as minimal as possible, while the energy efficiency of the vehicle should be as high as possible. Schaeffler meets these market requirements every day. With FAG in the chassis sector, Schaeffler develops, produces, and sells precisely the components that demanding car manufacturers need to bring their latest vehicles on the road.

FAG has always supplied wheel bearings that are particularly safe and reliable. FAG wheel bearings are used worldwide in cars and commercial vehicles, repeatedly proving their worth day in day out. At FAG, the focus of all product developments is always on finding the optimum interaction between all components. And that’s how the company keeps the world moving.

## 1.2 Why FAG wheel bearings are worth it

FAG has been an expert in precision bearings since 1883. The company's years of experience in manufacturing wheel bearings – a part that has to handle particularly high load – is a considerable advantage for garages, which benefit from FAG's expertise. Since 2005, FAG wheel bearings have been available in the spare parts market, and the manufacturer's wheel bearings are now among the most sought-after products of their kind.

Garage experts appreciate quality, which is why they rely on FAG's experience. For these experts, the durability and precision of the parts they install are particularly important because wheel bearings are crucial for safety. At FAG, quality is ensured at every stage of the manufacturing process – materials, development, production and testing all meet the most stringent requirements. FAG is also a supplier much in demand by car manufacturers, who also rely on the firm's excellent quality.

### Repair solutions – By experts, for experts

Innovations from FAG pave the way for the automotive industry. FAG not only invented and patented the ball grinding machine for perfect balls, for instance, but also the orbitally formed shoulder, which ensures that the bearing clearance is defined and set from the outset. This has made it easier and safer to replace wheel bearings in the garage.

And since FAG ensures that every repair can be carried out in the simplest possible manner, FAG packages include all of the accessory parts required to perform professional repair work, alongside the wheel bearing itself. Because FAG understands precisely how repairs are performed, the sets include the parts needed to ensure error-free work, making sure garage experts are always on the right track.

The snap ring and the face spline make it easier to assemble wheel bearings of Generation 2.1 and higher, thus ensuring greater safety and faster repairs, while the low friction torque seal (LFT) protects modern FAG wheel bearings effectively from contamination and ensures greater efficiency by reducing the amount of friction. For more information, see chapter 6.

FAG understands that time is money. Which is why FAG sets also contain non-verbal installation instructions where applicable, allowing you to get things done quickly using the tips. If you require support, the necessary technical information for items provided by FAG can be found on the REPERT garage portal.

### Advantages of FAG wheel bearings

#### Experience

FAG engineers are highly regarded throughout the industry and represent the ultimate guarantee for innovations that meet global standards such as the orbitally formed shoulder.

#### OE supplier and Schaeffler quality

FAG cooperates with car manufacturers already during the development stage. Spare parts from FAG have the same quality as the part installed by the vehicle manufacturer.

#### Practical orientation

FAG WheelSet or FAG WheelPro always contains precisely the parts that are needed for replacing the wheel bearing – no more and certainly no less! This is why it is quite common for more accessories to be included in the repair solution than the car manufacturer requires.

This decision is taken by FAG's specialists, who have years of experience in garages, based on their expert knowledge and following thorough research. After all, it's about providing the best assistance possible to the garage professional.

#### Safety

The quality of our wheel bearings and the corresponding accessories is an essential part of the safety concept of FAG. Since screws, nuts and all other parts are tailored to the wheel bearing and the vehicle, FAG repair solutions can be regarded as a holistic system.

Thanks to the various safety systems of the accessories, the wheel bearing

- is securely positioned in the steering knuckle
- remains under pre-load throughout its service life
- is guaranteed to keep its spherical running precision
- is not exposed to unnecessary wear and potential failure

Therefore, any garage using FAG repair solutions can feel confident when it comes to safety and reliability.



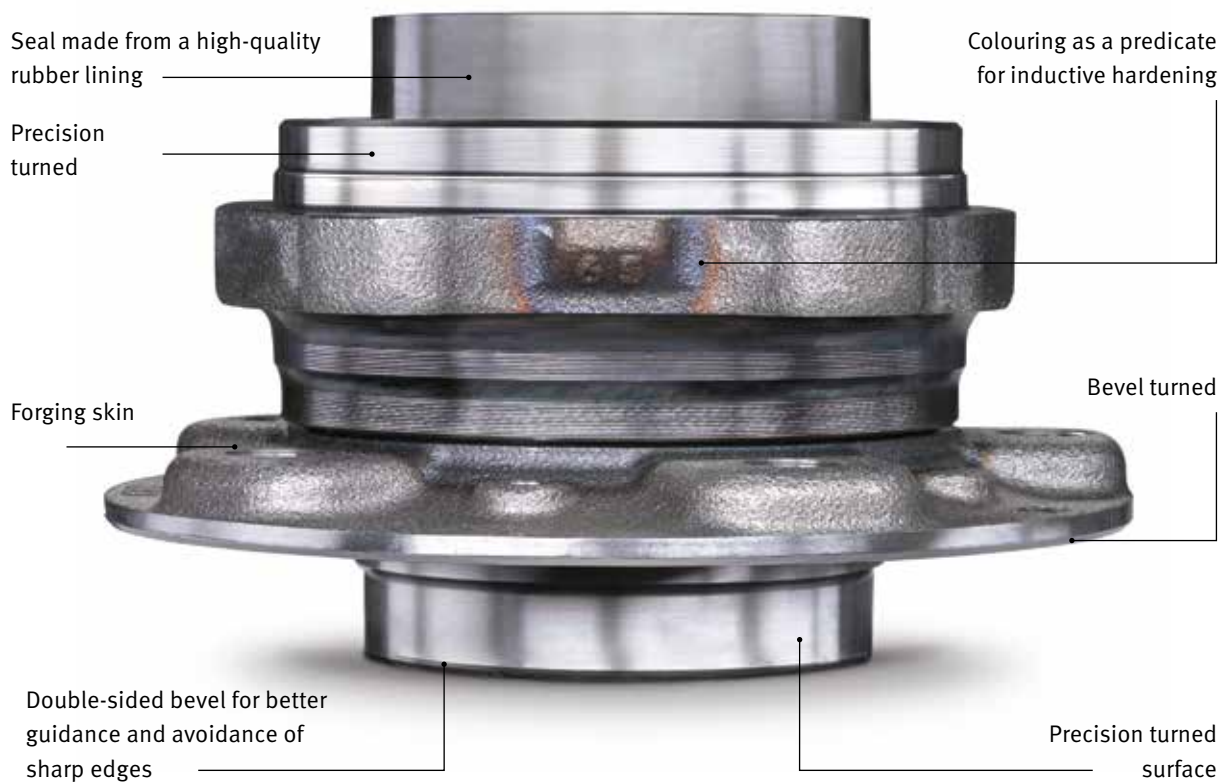

### 1.3 How to recognise quality

Wheel bearings are safety-critical components in a vehicle! FAG wheel bearings meet the highest safety requirements, and are known for this throughout the world. They offer the safety and quality needed for first-class repairs. Which is why it is important to understand the characteristics of original FAG spare parts:

#### Packaging

Make sure the packaging is unopened and original. FAG packaging always looks as shown here.

#### Parts in the packaging

In addition to the wheel bearing, all FAG wheel bearing repair solutions include additional parts such as screws and/or nuts, a bonus coupon from REPERT and, where applicable, non-verbal installation instructions.



#### Product quality

The surface characteristics of the wheel bearing also indicate its high production quality.

Each year, customs officers seize large volumes of counterfeit products. These are scrapped under strict security measures because these parts would never meet the safety requirements for modern vehicles. Therefore, make sure original spare parts are used. Only garages that use original parts can guarantee the quality of their repairs. Those that seek to save money on safety-critical parts are risking the lives of their customers.

## 2 All-rounder wheel bearing



### Function

Wheel bearings are an essential component of the chassis system. The load-bearing parts of the vehicle are termed the chassis (also known as the vehicle frame). These parts must support the functional elements, transmission, body and payload, and stabilise the vehicle against external and internal forces. The wheel bearing transfers the force of the transmission to the wheels and should therefore manifest as little friction as possible. At the same time, it bears the weight of the vehicle via the roller bearings.

In addition to simply transferring forces, wheel bearings are involved in various tasks in modern vehicles. Wheel bearings provide rotational speed signals for the increasing number of driver assistance systems in modern vehicles (like ABS or ESP) and transfer them to the control units.

#### Primary functions include:

- Enabling low-resistance rotations of the wheels
- Transferring axial and radial forces
- Support for wheel hub, wheel and brake disc or brake drum
- Sending rotational speed signals (in vehicles with driver assistance systems like ABS, ESP, etc.)

## Requirements

Wheel bearings are subject to differing loads in vehicles. Whether due to poor road surfaces, fast cornering, hitting a kerb, or in the worst case, potholes in bends, wheel bearings must sustain great stress. Vehicle weight is a further consideration in addition to these outside influences. While today's car manufacturers may strive to keep weight down as much as possible by using lighter materials, this is counterbalanced by the customer's comfort and safety needs. As a result, weight has risen, meaning the wheel bearings, too, are subject to greater loads.

Furthermore, demand for greater engine performance is also increasing, and wheel bearings must also be able to cope with the resulting higher speeds. In addition to safety, comfort and the service life of a wheel bearing, friction and temperature are also key factors that must be taken into account when developing bearings. And of course, there is also the issue of whether the wheel bearing is fitted to the front or rear axle – in other words, a driving axle or a non-driving axle.

### Active forces

#### Axial forces from:

- Cornering
- Hitting kerbs

#### Radial forces from:

- Acceleration, braking
- Potholes
- Poor road surfaces
- Vehicle weight

#### Requirements for wheel bearings:

- Precise wheel guidance
- Low friction
- Low weight for reduced CO<sub>2</sub>
- High bearing stiffness/rigidity (stability)
- Reduction in unsprung masses, which contributes to better driving dynamics
- Absorption of external forces
- Greater comfort (e.g. minimal noise)
- High quality and safety
- Long service life
- Thermal stability
- Corrosion resistance
- Low maintenance
- Simple assembly/disassembly
- Sustainability (environment and disposal)



$F_s$ : Lateral forces when cornering |  $F_b$ : Braking force |  $F_n$ : Normal force (weight force of the vehicle at a standstill)

### 3 Construction and function of roller bearings

Roller bearings, the generic term for all bearings that contain rolling elements, are produced in many different designs. Fundamentally, the construction of all such bearings is similar. They comprise two bearing rings with integrated races.

Rolling elements are situated between the rings, which roll in the races. Balls, cylindrical rollers, needle rollers, tapered rollers, and barrel rollers are used as rolling elements. A cage ensures that the rolling elements remain in position.

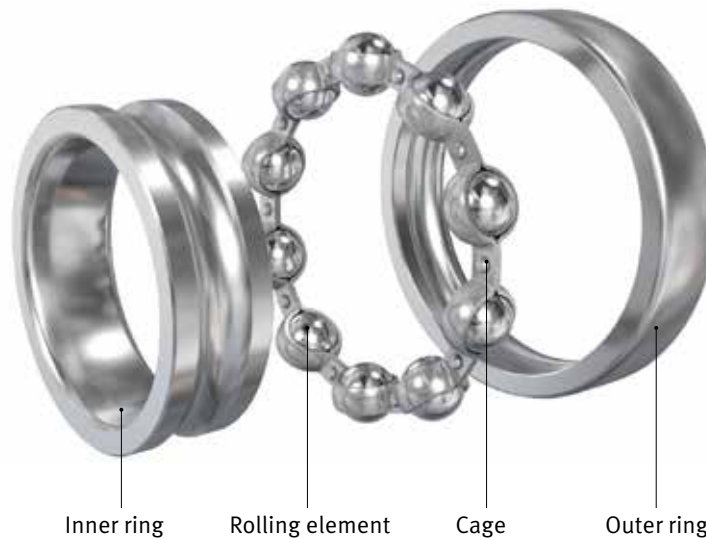

#### 3.1 Roller bearing types

Each type of roller bearing has characteristic properties that make it ideal for particular applications. However, it is difficult to define general rules when it comes to choosing the type of bearing because there are often several factors that need to be considered and weighed up against each other. For example, in addition to the type of exerted forces, speed, temperature, lubrication,

vibrations, installation, and maintenance have to be taken into account as well.

The following overview shows the basic designs of different bearing types. The name of the design type is based on the shape and, where applicable, the position of the rolling elements.

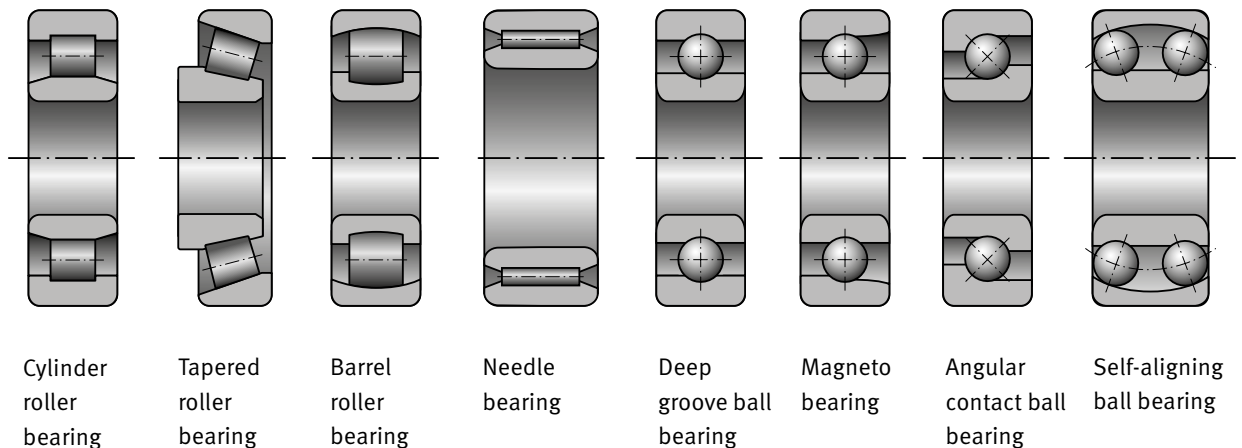

## 3.2 Roller bearing design

As described in chapter 2, both radial and axial forces act on vehicles. Wheel bearings must therefore be designed to withstand both of these active forces. For this reason, angular contact ball bearings are particularly suitable. Where high axle loads apply, tapered roller bearings are often used.

### Pressure angle

Essentially, each of the rolling elements of a ball bearing comes into contact with the inner and outer race at one point. The connection line of the contact points runs perpendicular to the races, and passes through the centre of the ball. The external stresses are transferred from one bearing ring to the other in the direction of these lines. This is termed the pressure line of the bearing. The pressure angle resulting from the pressure line and radial plane, as well as the spacing of the rows of rolling elements, determine how much load the bearing can assume.

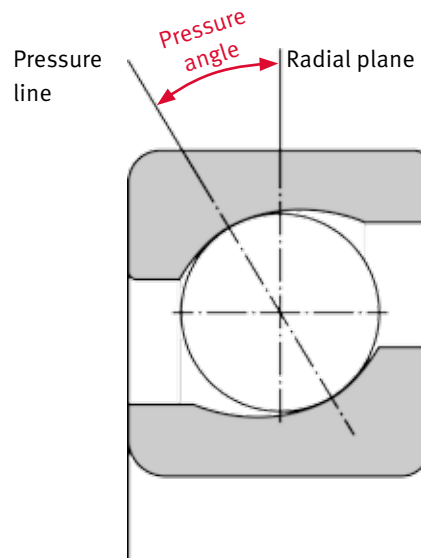

### Supporting base

If the pressure lines of each rolling element are extended to the bearing axis, the lines meet at two points. The distance between the two points is called the supporting base. The longer the supporting base, the more effectively axial forces can be absorbed that occur during cornering.

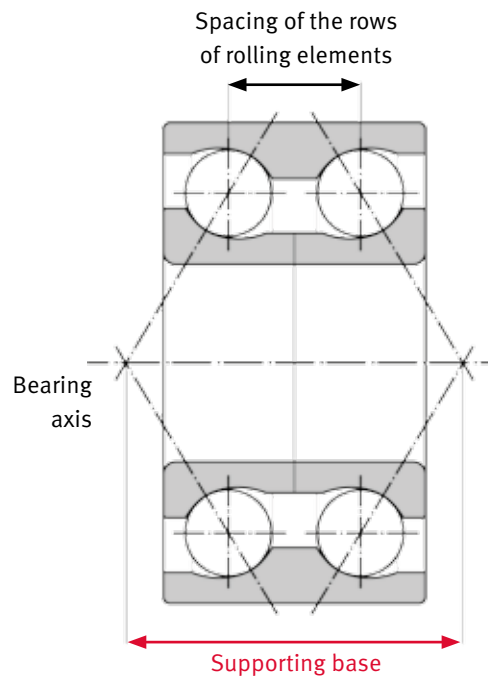

### 3.3 Advantages and disadvantages of tapered roller bearings and ball bearings

The decision as to whether to use tapered roller bearings or ball bearings as the wheel bearing is based on the properties of the respective bearing type. Balls are generally used in passenger cars. Because of their ability to absorb high radial forces, tapered roller bearings are often used in commercial vehicles.

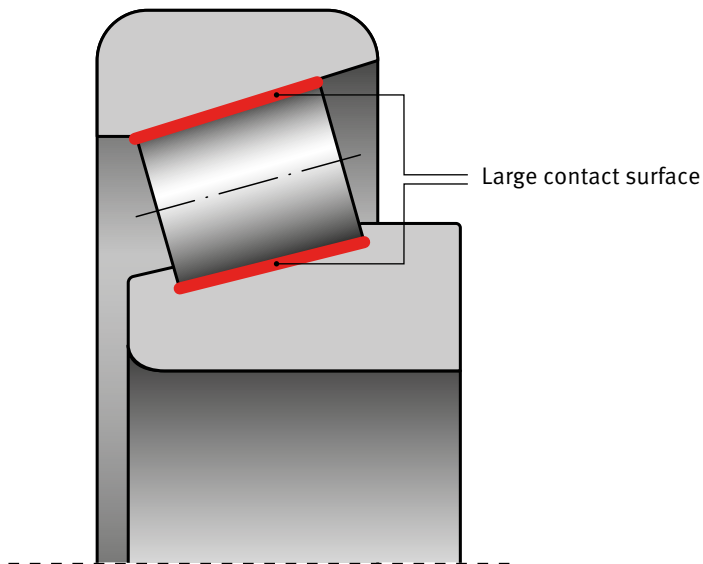

#### Tapered roller bearing

##### Advantages

- Can cope with high loads due to the large contact area of the rolling elements in the races

##### Disadvantages:

- Not suitable for high engine speeds
- Increasing heat due to large contact surface

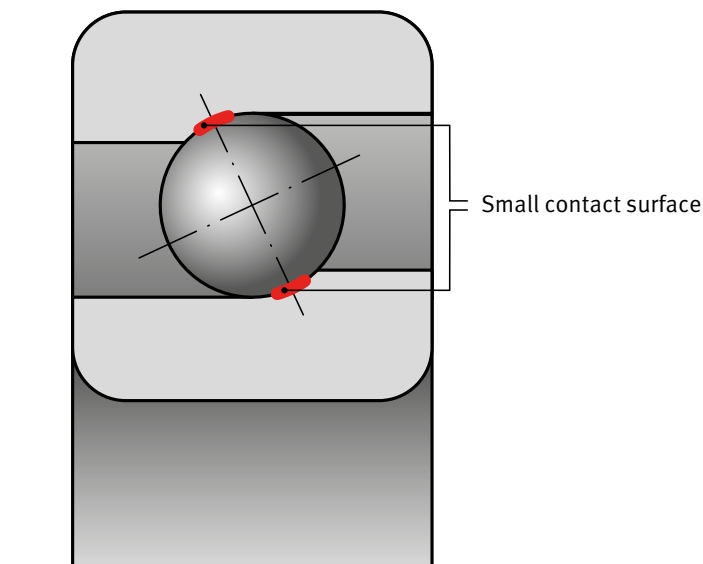

#### Ball bearing

##### Advantages

- Suitable for high engine speeds
- Low friction thanks to minimal contact area of the rolling elements in the races

##### Disadvantages:

- High surface pressure (the load is concentrated on the smaller contact area of the balls)

### 3.4 Construction of compact bearing units

Until the 1960s, the automotive industry exclusively used single-row bearings arranged in pairs. Over time, as the demands of car manufacturers increased, the first compact wheel bearing units went into series production.

This type of bearing is used almost exclusively in today's passenger cars. These "compact bearings" comprise an undivided outer ring, two inner rings, rolling elements, and a cage, and are pre-lubricated, sealed, and maintenance-free.



The first design of this compact bearing is known as the Generation 1 compact bearing, and even though its use is in decline in series production, it is still used today – including in high-performance vehicles.

Over the years, new generations were developed. These are known as the Generation 2 and 3. The Generation 2 has a flange designed either as a wheel hub or mounting flange on the axle carrier.

Generation 3 wheel bearings combine both flanges, which means that in the event of repairs, the wheel bearing simply has to be screwed to the steering knuckle.

#### Reasons for the development of the wheel bearing generations:

- Integration of functions of the surrounding components (e.g. flange, multipole encoder, seals)
- It is now easier to make aluminium wheel carriers. This is not uncritical in the case of press-fitted bearings
- Simplified assembly
- Subsequent setting of bearing clearance is not necessary (maintenance-free)
- Possible assembly and setting errors are reduced

## 3.5 How a wheel bearing works

### Driven axles

Wheel bearings used on driven axles are secured in or on the axle carrier. With most Generation 1 and Generation 2 bearings, the outer ring is pressed into the axle carrier. Generation 3 wheel bearings have an outer ring that is screwed onto the axle carrier. This means the outer ring is always secured and, together with the axle carrier, forms a single unit.

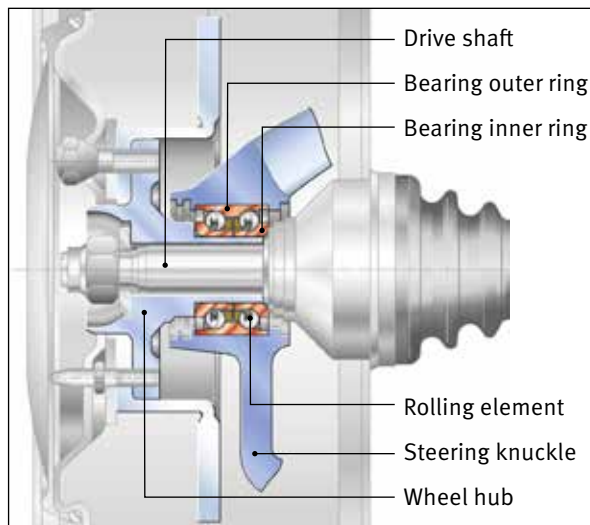

The wheel hub and the inner ring are force-locked connected with each other by means of press fit. Through a gearing system, the drive shaft engages with the wheel hub. Once the vehicle starts moving, the drive shaft turns, and therefore the wheel hub and the bearing.

The rolling elements located between the inner and outer rings roll in the races. The cage ensures that the rolling elements are retained in the pre-defined position in relation to one another, preventing the balls from rubbing. The load is evenly distributed in the wheel bearing.

Grease inside the wheel bearing ensures that friction and therefore the temperature are minimised, thus preserving the long service life of the wheel bearing's components. Additional seals keep out dirt and moisture, and prevent the grease from leaking out.

### Non-driven axles

The essential function of the wheel bearing is the same. The only difference is that the wheel bearing is not driven by a drive shaft. In these instances, the wheel bearing is either located on an axle journal or likewise in or on the axle carrier. Due to the different designs, both the outer and the inner ring can rotate, while the other ring remains stationary in each case.

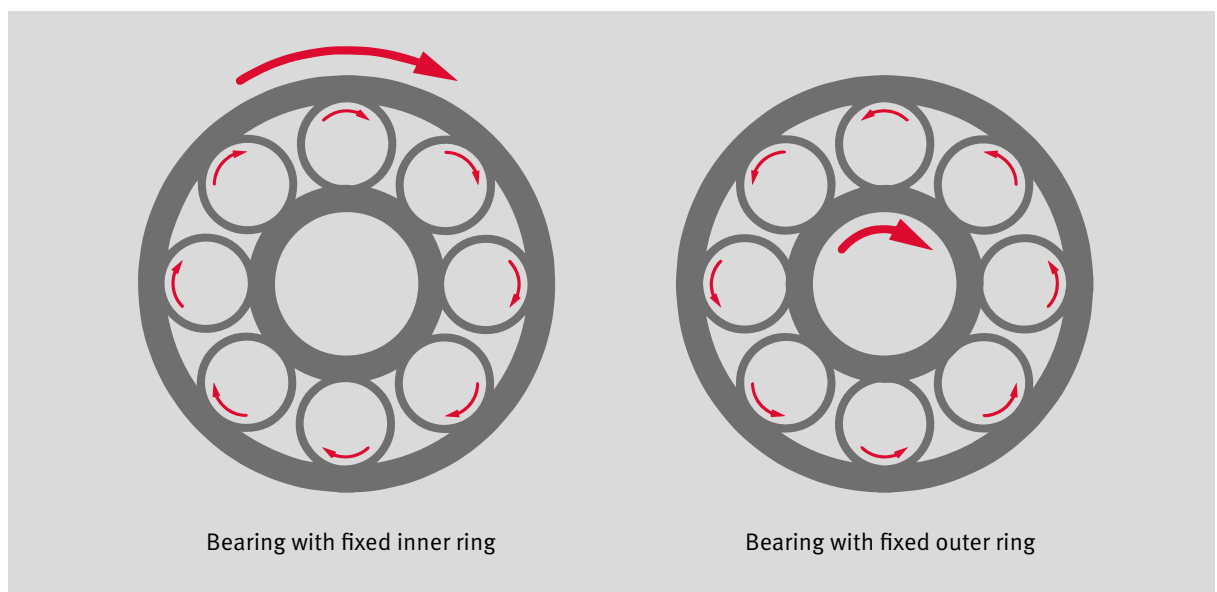

Bearing with fixed inner ring

Bearing with fixed outer ring





### 3.6 Bearing clearance and play

In the case of vehicles with two inversely installed single tapered roller bearings, the bearing clearance must be checked and if necessary set during an inspection or as part of brake repairs for example.

In most cases, this type of bearing is found on non-driven axles. The outer rings are pressed into the bearing seat of the wheel hub or the brake disc/drum. If either is removed from the steering knuckle during disassembly, the inner bearing ring drops out with the rolling elements or remains on the steering knuckle. Before installation, it is therefore necessary to clean and re-grease everything, and then set the bearing clearance. The specifications provided by the vehicle manufacturer must also be strictly followed.



In the case of compact bearings, it is no longer necessary to set the bearing clearance during maintenance. However, if the wheel bearing has to be replaced, the specifications regarding the tightening torque must be followed after installation as the bearing clearance is set only once.



#### Why is it necessary to set the bearing clearance?

First, a distinction must be made between bearing clearance and bearing play.

Bearing clearance is the measure by which one bearing ring can be offset against another in a radial direction (radial clearance) or in an axial direction (axial clearance) without load, that is, in its uninstalled state. This measure is preset by the design.

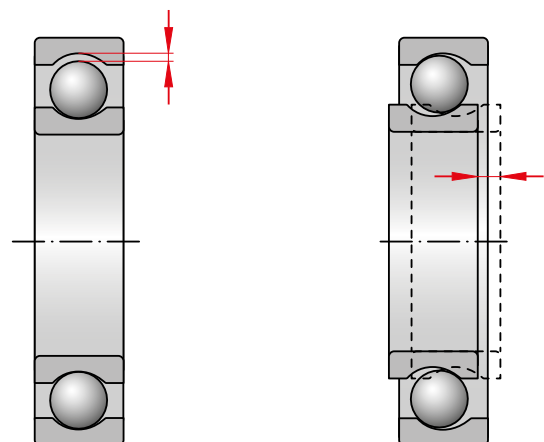

Radial clearance

Axial clearance

Bearing play on the other hand is the measure by which the inner ring moves in relation to the outer ring in both radial and axial directions when placed under load.

Once the wheel bearing is installed, the bearing clearance changes as a result of the tight fit. To ensure the rolling elements are in the correct position from the outset, the bearing clearance must be set. Since friction and heat generate further expansion during driving, it is vital that the setting specifications are closely followed, otherwise, the bearing could fail prematurely. If the play is insufficient, friction increases significantly, and the service life of the bearing is reduced to a great extent. However, if the play is too high, the load will not be distributed evenly across the rolling elements. Appropriate rigidity of the bearing is not given.

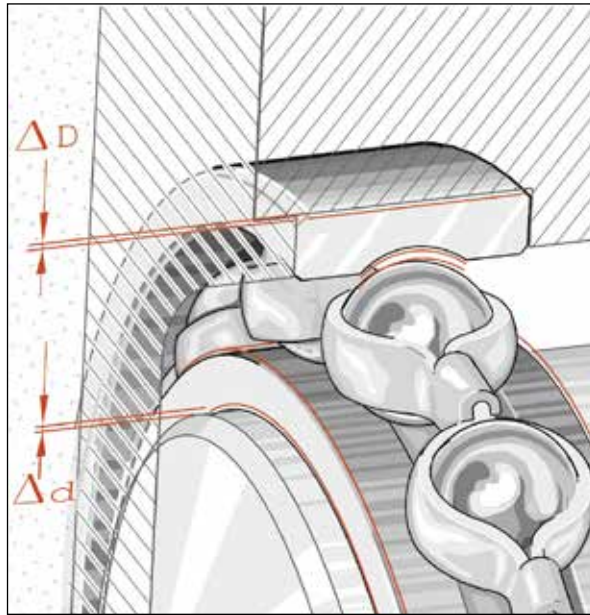

## Setting the bearing play

### Tapered roller bearing

In the case of tapered roller bearings, the setting is normally performed by rotating the wheel and hand tightening the axle nuts. The nuts are then loosened again until the thrust washer is absorptively moving in radial direction. There are cases where the vehicle manufacturer deems the use of a dial gauge necessary.

### Compact bearings

After a new Generation 1 or Generation 2 compact bearing has been installed, the axle nuts or axle screw must be firmly tightened to a tightening torque. This tightening torque is specified by the vehicle manufacturer. The overall connection of axle shaft, wheel bearing and wheel hub is pretensioned. This sets the bearing play.

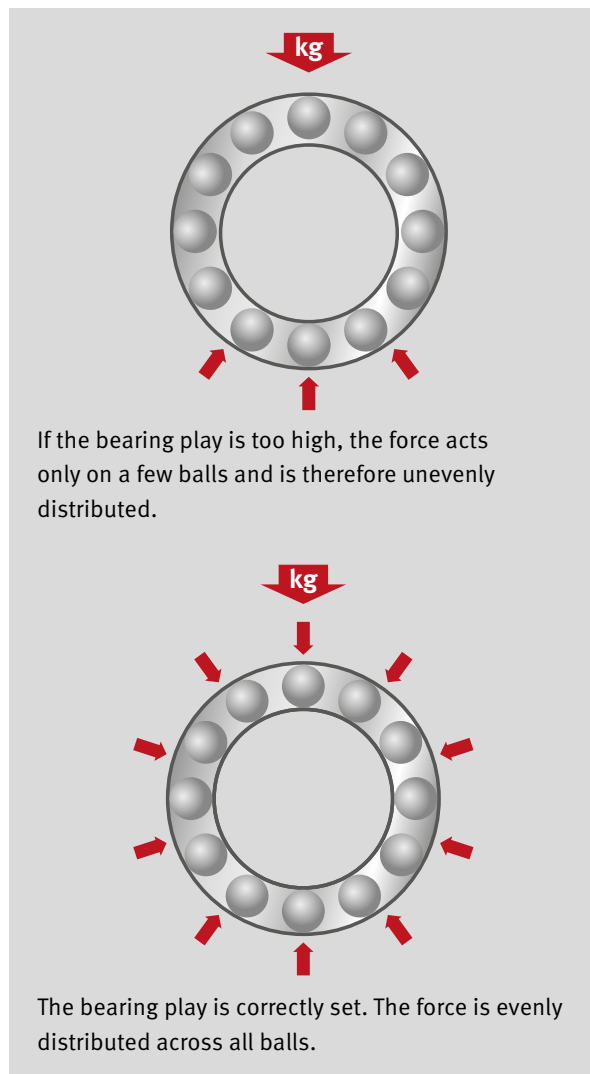

## 3.7 Lubrication



### Why lubrication?

The primary task of roller bearing lubrication is to minimise friction between the rolling elements and the race with the aim of increasing the service life of the bearing. In addition to protecting against corrosion, the lubricant also supports sealing. The grease ensures that the seal lip is lubricated, which reduces friction.

### Specifically tailored to every load

At FAG, high-quality greases that can effortlessly withstand driving forces are used for lubrication. FAG develops suitable roller bearing lubricants together with renowned manufacturers. These are subjected to a range of in-house tests in a special lubrication laboratory, where the greases are tested for factors including service life, friction and wear under high loads.

Since every type of roller bearing is used in the widest range of applications, the grease must also have the appropriate properties.

### The choice of the right grease depends on various factors:

- Temperature
- Friction
- Load
- Speed
- Vibrations
- Seal support

Generation 1 to Generation 3 wheel bearings are pre-greased and sealed. The grease is designed to fulfil its purpose over the entire service life.

Single tapered roller bearings on the other hand have to be re-lubricated whenever they are uninstalled and re-used, for example during brake repairs. Following such procedures, it is vital that the grease is re-applied between the rolling elements.

In most garages, standard commercial multi-purpose greases are used that are marked as “wheel bearing grease”.

### 3.8 Seal systems

Seals are a key component of the wheel bearing system. On the one hand, they prevent lubricants leaking out of the bearing, and on the other, they prevent dirt and moisture entering the bearing.

With Generation 1 to Generation 3 wheel bearings, the seals have multiple seal lips that come into contact with the inner or outer ring. They are designed like this to ensure that the bearing remains sealed over its entire service life, while also minimising friction.

In vehicles that employ driver assistance systems, the wheel bearing generally records and transfers rotational speed signals via a multipole encoder located behind the seal. An encoder element is attached to its support ring, which is usually made from sheet steel. This element is reciprocally magnetised in the production process. Together with the sensor, the different poles deliver a signal during driving that can be processed as a rotation and speed signal by the various control devices.

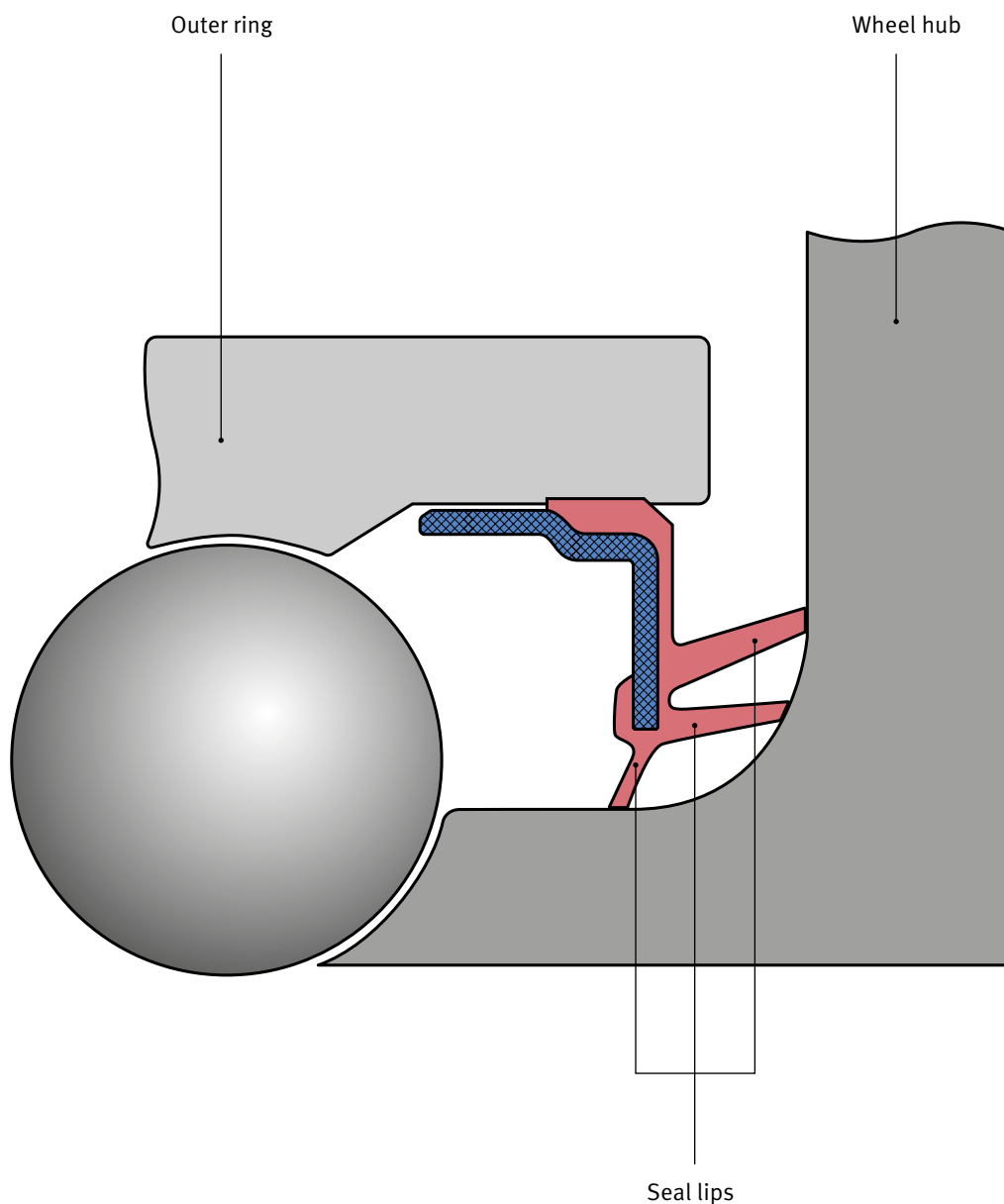

### 3.9 Rotational speed signal reading

As indicated in chapter 3.8, rotational speed signals are being increasingly transmitted by wheel bearings. A multipole encoder is often integrated into the seal for this purpose. The rotational speed signal is recorded via corresponding sensors, and used by the various control devices.

However, there are also vehicles in which the encoder or impulse transponder ring is not located in the wheel bearing, but on the drive shaft or even in the wheel hub.

And conversely, in some Generation 3 bearings, all of the sensors are located in the wheel bearing unit.

Thus, there are no limits to the range of options, and it is therefore a matter of space and the manufacturer's requirements as to which type of sensor system is used.



**The rotational speed signal is used for various driver assistance systems. Often, vehicle manufacturers use different terms to refer to these. Below is a small selection:**

- Anti Blocking System (ABS)
- Anti Slip Regulation (ASR)
- Electronic Stabilisation Program (ESP)
- Dynamic Stability Control (DSC)
- Vehicle Stability Control (VSC)
- Vehicle Stability Assist (VSA)
- Traction Control (TRC)
- Dynamic Traction Control (DTC)
- Traction Control Support System (TCSS)

The type of sensor used also differs. A distinction is made between passive and active sensors in this respect. Passive sensors, also termed inductive sensors, deliver an induction signal, which is represented in the form of a wavy line on an oscilloscope.

A coil with a permanent magnet and an incremental encoder are needed to generate the signal. Both are arranged so that there is a clear gap between them. As the incremental encoder, which is shaped like a gear-wheel, moves, the sprocket and gap move alternately beneath the coil, which changes the magnetic field and creates induction voltage in the coil.

Analogue signal recording like this is mostly used in older vehicles with ABS. Since the signal can only be used at speeds above approximately 7 km/h, additional systems such as stability control and traction systems cannot effectively use this signal type.

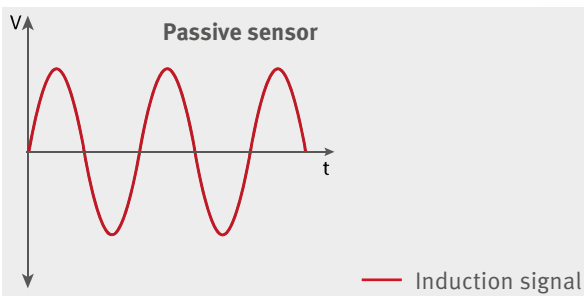

Modern active sensors deliver signals right up until the vehicle comes to a standstill. Even the direction of rotation can be detected. This presents a range of possibilities, including for CAN bus systems like automatic parking, navigation systems, transmission systems, and engine systems.

Sensors of these systems work according to the Hall principle for example. The signal is delivered by a multipole encoder, which is reciprocally magnetised and situated in or on the wheel bearing. The sensor is operated with a supply voltage and delivers a digital output signal that can be directly processed by the control unit. This is shown as a square-wave signal in various variants on an oscilloscope.

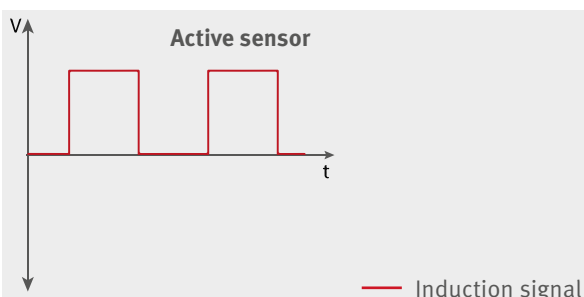

Generation 3 wheel bearing with integrated sensors

## 4 Wheel bearing generations

Single tapered roller bearings arranged in pairs are becoming increasingly uncommon today. They are being replaced by wheel bearing compact units that are able to take on more and more peripheral functions from generation to generation. This trend is also evident in the garage environment. For example, in the past, garages had to lubricate tapered roller bearings during assembly, and regularly perform setting work during an inspection. This isn't necessary with compact bearings.

The following overview illustrates wheel bearing development over the years, with all wheel bearing types currently in use in modern vehicles.



1



2



3



4



5



6



7



10



11



**1 Standard tapered roller bearing**  
Dismountable tapered roller bearing

**2 Generation 1**  
Double-row angular ball bearing with/without multipole encoder

**3 Generation 1T**  
Double-row angular tapered roller bearing with/without multipole encoder

**4 Generation 1**  
Double-row angular ball bearing with snap ring, with/without multipole encoder

**5 Generation 2**  
Double-row, sealed angular ball bearing with conventional encoder

**6 Generation 2**  
Double-row, sealed angular ball bearing with multipole encoder

**7 Generation 2D**  
Double-row, sealed tapered roller bearing

**8 Generation 2.1**  
Double-row, sealed angular ball bearing with orbitally formed shoulder, multipole encoder and snap ring

**9 Generation 2.1**  
Double-row, sealed angular ball bearing with orbitally formed shoulder, multipole encoder and snap ring

**10 Generation 3**  
Double-row, sealed angular ball bearing with orbitally formed shoulder

**11 Generation 3**  
Double-row, sealed angular ball bearing with orbitally formed shoulder, multipole encoder and sensor

**12 Generation 3.2**  
Double-row, sealed angular ball bearing with orbitally formed shoulder, multipole encoder

**13 Generation 3.2**  
Double-row, sealed angular ball bearing with orbitally formed shoulder, multipole encoder, face spline and LFT



## 4.1 Generation 1



The Generation 1 was the first wheel bearing unit on the market. It is available with both ball and tapered rollers.

### Generation 1 properties (ball bearing):

- Double-row angular contact ball bearings
- Compact unit, cannot be disassembled
- 1 bearing outer ring
- 2 bearing inner rings
- Pre-greased and maintenance-free
- Sealed
- Preset bearing clearance
- With and without multipole encoder
- With and without snap ring to secure on axle carrier
- Used on front and rear axle

### Generation 1T properties (tapered roller bearings):

- Double-row tapered roller bearings (inversely installed)
- Compact unit, cannot be disassembled
- 1 bearing outer ring
- 2 bearing inner rings
- Pre-greased and maintenance-free
- Sealed
- Preset bearing clearance
- With and without multipole encoder
- With and without snap ring to secure on axle carrier
- Used for high axle loads
- Frequently used in light commercial vehicles

**Repair notes:**

Generation 1 wheel bearings do not have a flange. In most cases, they are fitted to the steering knuckle when used on the front axle, where the outer ring is fixed in the bearing seat. This should first be checked before the new bearing is installed. It is important to note the wear pattern.

If widespread dark patches appear in the bearing seat, this indicates oval forming. A visual inspection and measurement of the roundness is recommended in this respect.

If in doubt, the entire steering knuckle should be replaced, as otherwise the outer ring will no longer be firmly attached during driving and damage may occur to the axle suspension.

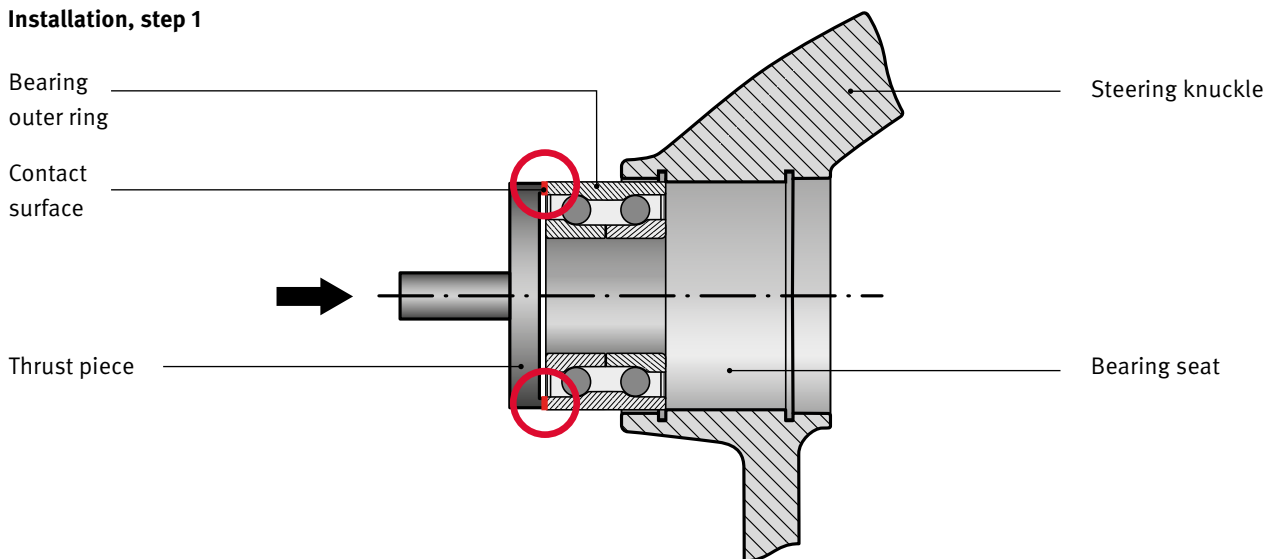
**Installation, step 1**

The bearing is normally pressed in via the fixed bearing ring (in most cases, the outer ring). The corresponding thrust pieces are used in this respect.

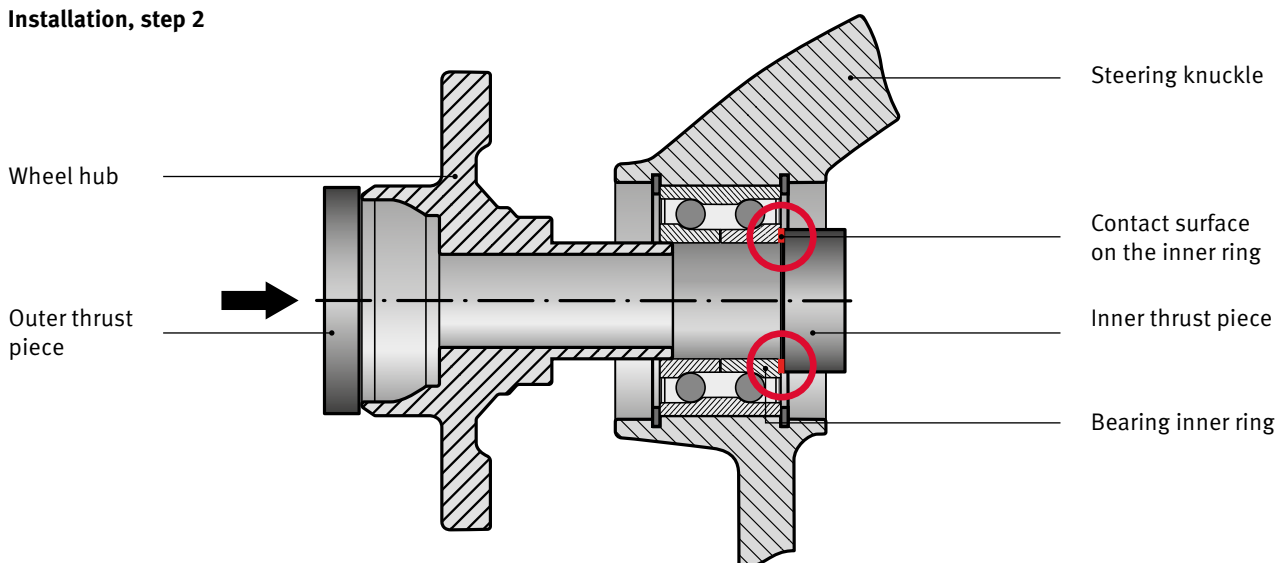
**Installation, step 2**

When pressing in the wheel hub, the inner ring must be supported with a suitable thrust piece.

### Wheel bearing with ABS

Prior to installation, the multipole encoder must be checked. The side with the multipole encoder faces inwards (sensor side). The encoder must be checked thoroughly to ensure there is no damage prior to installation.



### Important notes

- Adhere to the tightening torque specified by the vehicle manufacturer so that the bearing clearance is correctly set
- Install the circlip with the opening facing down. This allows any moisture to flow out more effectively
- In the case of bearing designs with an integrated snap ring, it must be ensured that the ring fully locks into the groove in the axle carrier (use the corresponding tools or installation sleeves)
- Observe the fitting instructions in the packaging
- Check the bearing seat on the axle carrier, and clean before assembly
- Do not place wheel bearings with multipole encoders near magnets
- If the wheel bearing is replaced using a special tool, the steering knuckle does not have to be removed, which also means axle alignment is not required
- Use all supplied accessory parts to ensure safe and secure seating

## 4.2 Generation 2



Generation 2 wheel bearings are compact wheel bearing units with a flange. This either takes the form of a wheel hub or mounting flange. There are a number of different designs.

### Generation 2 properties:

- Double-row angular contact ball bearings (rarely: double-row tapered roller bearings)
- Compact unit, cannot be disassembled
- Compact bearings with an additional flange (wheel hub or mounting flange)
- Rotating inner or outer ring
- Pre-greased and maintenance-free
- Sealed
- With snap ring (Generation 2.1)
- The bearing clearance is set using the tightening torque of the axle shaft screw/nut
- Predefined bearing clearance for wheel bearings with orbitally formed shoulder that are used on non-driven front axles (e.g. Mercedes-Benz Sprinter, Vito, Viano, VW Crafter)
- With and without orbitally formed shoulder (see chapter 6.1)
- With and without multipole encoder
- Multipole encoder behind the seal or conventional encoder (incremental encoder)
- For driven and non-driven axles
- With inner gearing (for driven axles)

**Repair notes**

On Generation 2D wheel bearings, the outer ring is designed as a mounting flange. If this is the case, only this must be firmly tightened. The specifications of the vehicle manufacturer must be followed in this respect.



For Generation 2.1 wheel bearings with wheel hub and rotating inner ring, the wheel bearing must only be pressed in over the outer ring. To get hold on the outer ring, however, special tools are needed (e.g. clamps – see the picture below). These tools allow the bearing to be pressed into the bearing seat using the outer ring. For designs with a snap ring (as shown), the outer ring is additionally secured as it can securely engage in the groove on the steering knuckle.



**Note:**

The bearing must never be pressed in via the wheel hub without clamps! Otherwise, the bearing could be damaged during installation. The use of clamps alone can ensure that the snap ring is fully locked into the groove on the axle carrier. If this is not followed, the bearing could work loose from the bearing seat. This presents a risk of fatal injury!



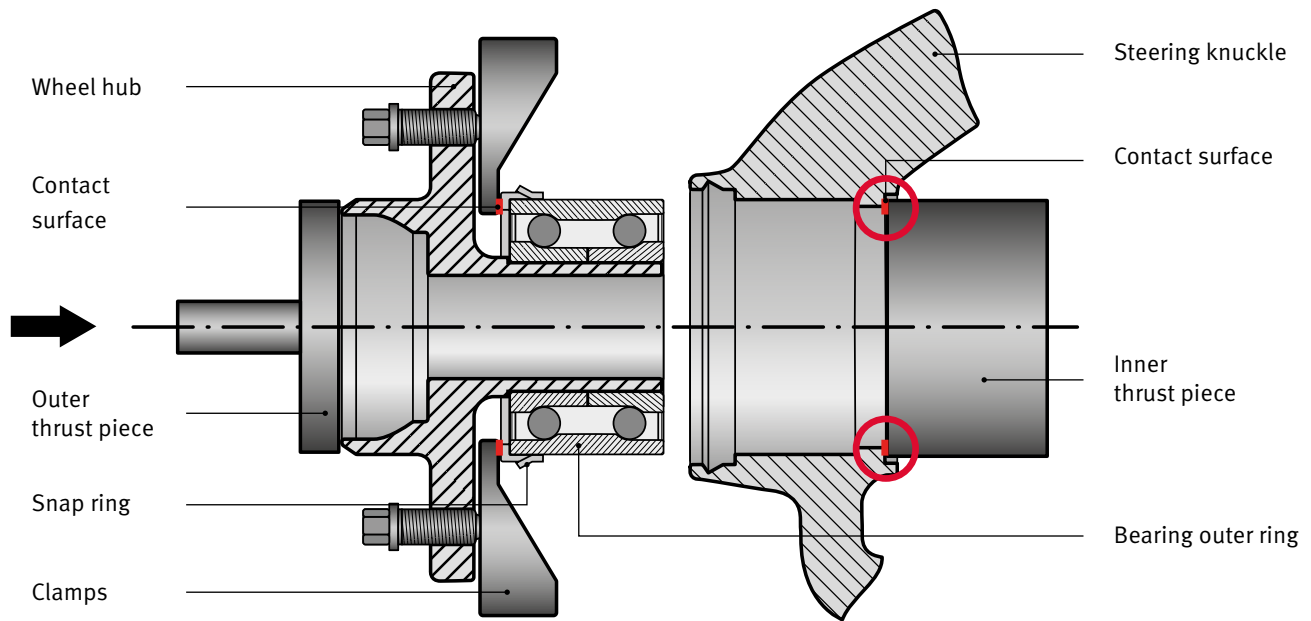

First, the clamps must be attached.

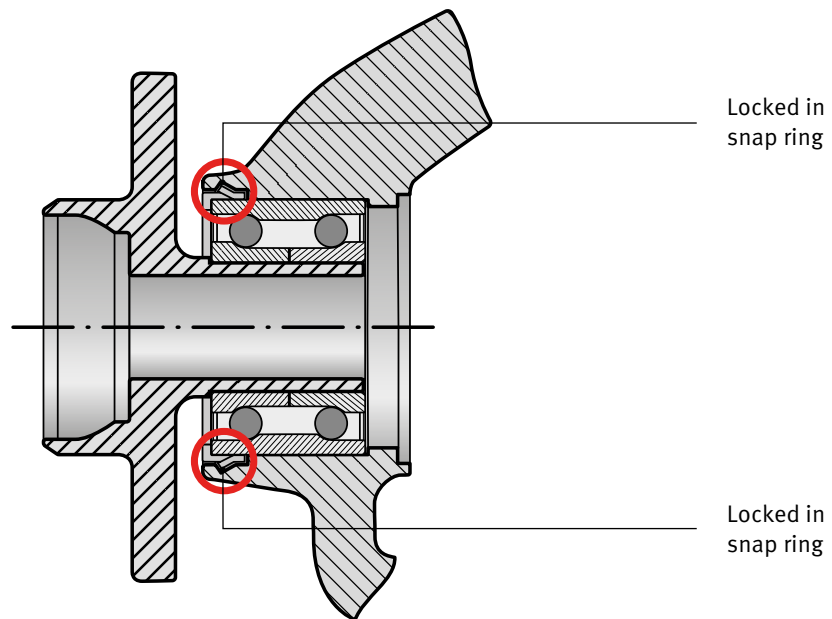

The snap ring must lock into the groove on the steering knuckle with an audible click.

### 4.3 Generation 3



Generation 3 wheel bearings have two flanges. One serves as the wheel hub, the other secures the bearing unit to the axle carrier.

**Generation 3 properties:**

- Double-row angular contact ball bearings
- Compact unit, cannot be disassembled
- Complete wheel bearing unit with two flanges (for securing to the axle carrier and for the brake disc/wheel)
- Pre-greased and maintenance-free
- Sealed
- Pre-set bearing clearing
- With or without complete ABS sensors
- With orbitally formed shoulder (see chapter 6.1)
- With gearing on the inner ring for driven wheels
- With face spline possible (see chapter 6.3)
- For driven and non-driven axles

**Repair notes:**

- Simple assembly possible as no special tools required for removal or press-fitting
- The tightening torques specified by the vehicle manufacturer must be observed
- Use all supplied accessory parts to ensure safe and secure seating



## 5 Repair solutions for the garage

### How can a wheel bearing be damaged?

At FAG, all wheel bearings are designed for the service life of the vehicle. Their longevity, however, can be greatly reduced by disruptive influences:

- Poor road conditions (potholes, etc.)
- Storm conditions
- Hitting kerbs
- Excessive loading
- Incorrect installation/assembly errors
- Using incorrect tools
- Errors associated with surrounding parts (e.g. axle carrier)

### Defective wheel bearing?

Despite maximum robustness, premature wheel bearing failures or damage due to disruptive influences cannot be ruled out. Characteristic indications:

- Overheating of the bearing
- Unusual running noise
- Rough running
- Illumination of ABS or ESP warning lamp
- Jerking of the steering wheel
- Vibration in the brake pedal
- Vehicle instability during straight-line driving
- Brief, loud noise when parking or driving through tight bends at low speeds

Diagnosis based on noise is the most challenging. Often such noise can have an entirely different cause, e.g. defective bumpers, spring strut bearings, tyres, and joints.



### FAG WheelSet – by experts, for experts

As FAG ensures that every repair can be carried out in the simplest possible manner, FAG packaging includes all of the accessory parts required to perform professional

repair work, alongside the wheel bearing itself. These additional parts make all the difference. The nuts and bolts are equipped with various locking systems and are perfectly tuned to the corresponding wheel bearing and vehicle.

An ideal repair solution is only as effective as its individual parts, which is why these parts must be of the highest quality and be provided together with the relevant services. Schaeffler's repair solution ensures that the wheel bearing:

- Sits securely in the steering knuckle
- Remains tensioned throughout the duration of its service life
- Runs as true as possible
- All components required for safe assembly are contained
- Is protected from unnecessary wear and potential failure

Wheel bearings and their accessory parts together form a system. Quality and intelligent accessories are essential building blocks in the overall safety design. Together, they form the FAG security system – a system that you can always rely on.



### FAG WheelPro – The smart solution for long-lasting vehicles

With 60 items for approximately 114 million vehicles in Europe, this product is tailored to customers' safety needs even for older vehicles at an attractive price. In high-performance vehicles, it is possible that the second wheel bearing on the same axle may also fail after a short amount of time.

The FAG WheelPro repair solution is a preventive maintenance procedure for the entire axle, saving the customer time and money in the long run. And this service is available for almost a third of vehicles in Europe!

## 6 Patents and innovations

With over 2,000 patent applications a year, Schaeffler can claim top spot when it comes to innovation. The following developments from FAG in the area of wheel bearings are worthy of particular mention.

### 6.1 Orbitally formed shoulder

All wheel bearings must be set after installation. In the case of compact bearings, this is done by tightening the central nuts or central screw to the manufacturer-specified tightening torque immediately after assembly. During the service life of the wheel bearing, a wide range of factors can affect the overall connection of axle shaft, wheel bearing, and screw or nut. The result: bearing clearance increases, which can lead to premature failure of the bearing.

The orbitally formed shoulder ensures a solid connection of the hub and bearing rings, which reliably sets the required bearing clearance. This significantly reduces potential assembly errors. The orbitally formed shoulder is a worldwide standard in wheel bearing production.

During production, a “riveting pin” moves back and forth on the cold steel to transform the rear section of the wheel hub. Tensioning the bearing assembly sets the required bearing clearance, which remains constant over the lifetime of the bearing. The orbitally formed shoulder is used in Generation 2 and Generation 3 compact bearings.

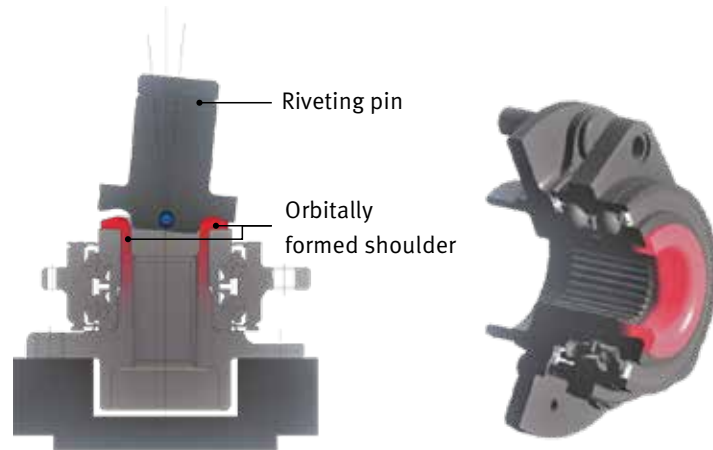

## 6.2 Snap ring

Most Generation 1 wheel bearings are secured against axial movement in the axle carrier with a circlip. Rings are used that can be assembled and disassembled in a groove in the axle carrier using pliers.

Generation 2 wheel bearings have a flange that often serves as the wheel hub. This means it is not possible to mount a standard circlip.

To safely secure the wheel bearings in the axle carrier, FAG therefore developed a circlip for Generation 2 wheel bearings – the “snap ring”. This is connected to the outer ring and locks into the corresponding groove in the axle carrier during assembly.

The snap ring is used with some Generation 1 bearings and with most Generation 2 bearings.

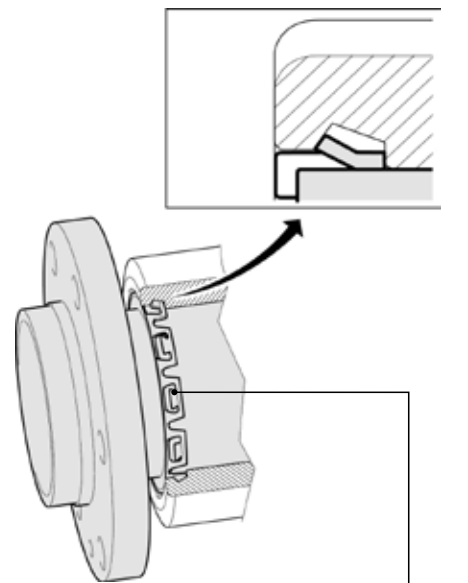

Snap ring



### 6.3 Face spline

Usually, the forces are transferred between the drive shaft and wheel hub via a radial gearing system. To meet vehicle manufacturer's growing CO<sub>2</sub> reduction requirements, a new transfer variant was developed.

With the patented face spline, FAG has developed a wheel bearing that

- simplifies assembly,
- increases the transferable torque by 50%,
- saves 10% of weight, thus reducing CO<sub>2</sub> emissions, and
- increases the driving dynamics of the vehicle.

The face spline is positioned axially on the drive shaft and at the transmission-side end of the wheel hub. This is realised thanks to the larger diameter of the gearing crown. It is used on Generation 3 wheel bearings. During production, the orbitally formed shoulder and face spline are made in a single step. The riveting pin, which forms the orbitally formed shoulder with staggered movements, also forms the face spline at the same time.



Face spline on the hinged bell of the drive shaft



Face spline on the orbitally formed shoulder

Seal lip, which prevents corrosion in the face spline

## 6.4 Low friction torque seal (LFT)

There are numerous variants of wheel bearing seals. All have multiple seal lips that seal the contact surface with the rotating bearing ring. When these touch, friction occurs, which on the one hand is necessary, and on the other is obstructive.

FAG has therefore developed a low friction torque seal with fewer seal lips. At the same time, a seal concept was designed that resembles a labyrinth.

The design prevents external moisture and dirt nearing the delicate seal lips, which means the seal now only needs two seal lips. A small detail when considering the component as a whole. But with huge benefits. Bearing friction is reduced by 50%, which has a positive impact on fuel consumption and CO<sub>2</sub> emissions.

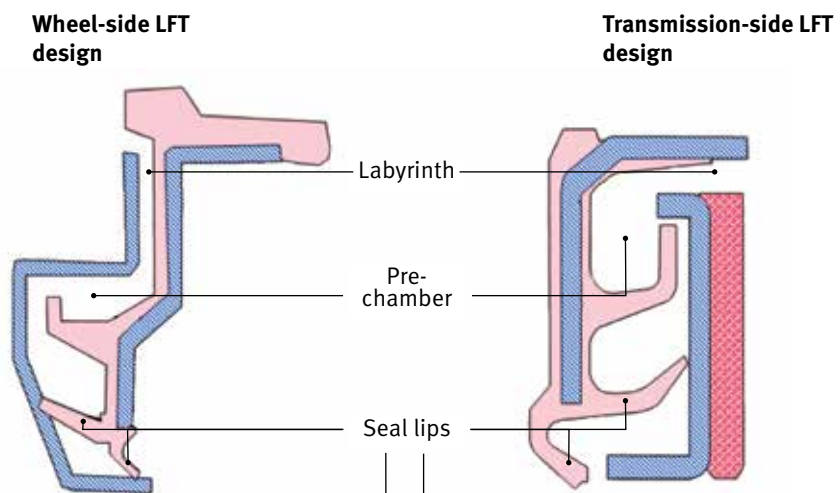

## 7 Outlook and innovative strength of FAG

Mobility of the future demands new concepts. Together with Ford, Schaeffler engineers have developed a new transmission concept.

With the “wheel hub drive”, all transmission components have now been moved to the wheel. The E-Wheel-Drive thus opens up completely new opportunities in automotive engineering and is pioneering when it comes to electrically powered vehicles.

### Universally applicable

Everything needed for driving, braking and safety is now housed in the wheel. The vehicle platform on the other hand contains the battery, climate control, electronics and communication systems. This gives plenty of leeway for completely different chassis – from the smallest runabouts to minibuses, the Schaeffler E-Wheel-Drive can be used anywhere.

### Easier parking

Thanks to the possibility of a 90° steering angle, parking is possible even in the tiniest parking spaces.

### Less assembly space

By moving the transmission technology to the wheels, more room is freed up in the vehicles. As a result, a two-person car, for example, now has room for four.

### Properties (as at 12/2016)

Torque:	350 Nm permanent 700 Nm peak
Power:	33 kW permanent 40 kW peak
Voltage:	360 V – 420 V
Construction volume:	16 litres
Weight:	53 kg
Water cooling:	Converter & engine

And developments continue here too: the successes of today are the impetus for tomorrow's developments.



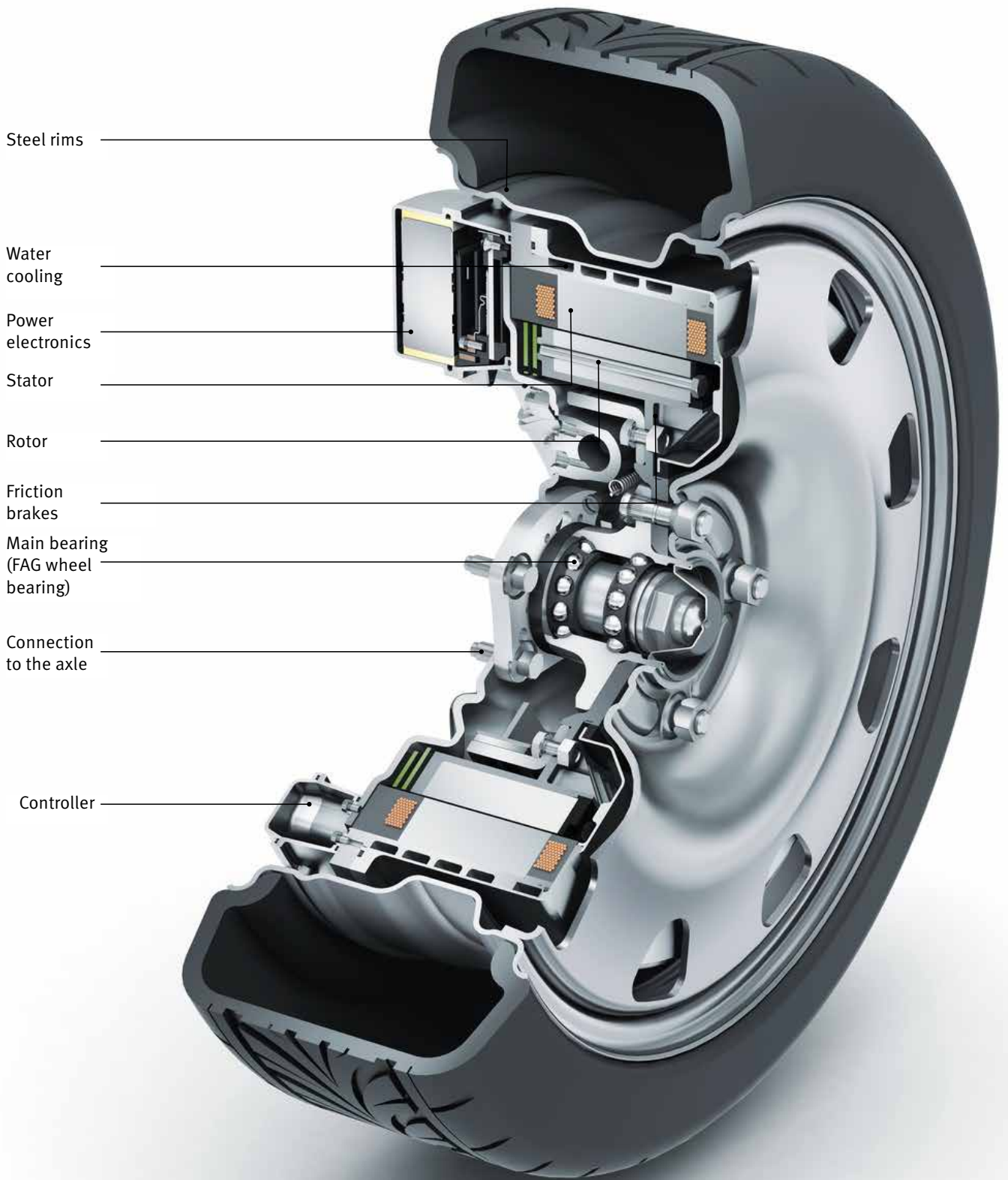

Steel rims

Water cooling

Power electronics

Stator

Rotor

Friction brakes

Main bearing (FAG wheel bearing)

Connection to the axle

Controller

